



Cambridge IGCSE™

CANDIDATE
NAME

--

CENTRE
NUMBER

--	--	--	--	--

CANDIDATE
NUMBER

--	--	--	--



MATHEMATICS

0580/32

Paper 3 (Core)

May/June 2020

2 hours

You must answer on the question paper.

You will need: Geometrical instruments

INSTRUCTIONS

- Answer **all** questions.
- Use a black or dark blue pen. You may use an HB pencil for any diagrams or graphs.
- Write your name, centre number and candidate number in the boxes at the top of the page.
- Write your answer to each question in the space provided.
- Do **not** use an erasable pen or correction fluid.
- Do **not** write on any bar codes.
- You should use a calculator where appropriate.
- You may use tracing paper.
- You must show all necessary working clearly.
- Give non-exact numerical answers correct to 3 significant figures, or 1 decimal place for angles in degrees, unless a different level of accuracy is specified in the question.
- For π , use either your calculator value or 3.142.

INFORMATION

- The total mark for this paper is 104.
- The number of marks for each question or part question is shown in brackets [].

This document has **16** pages. Blank pages are indicated.

- 1 (a) Paul has a set of 8 cards, each with a number written on it.
The numbers on the cards are 1, 1, 2, 3, 3, 3, 4, 5.
One card is taken at random.

Write down the probability that the number on the card is

- (i) 1,

..... [1]

- (ii) an odd number,

..... [1]

- (iii) a prime number,

..... [1]

- (iv) a number less than 6.

..... [1]

- (b) Dina has a set of 12 cards.
These are the numbers on the cards.

3 4 1 3 2 1 3 4 2 2 1 3

Work out

- (i) the median,

..... [2]

- (ii) the mode,

..... [1]

- (iii) the mean,

..... [2]

- (iv) the range.

..... [1]

- (c) Helena has a different set of cards.
She takes one card at random and records the number shown.
She does this 50 times.
The results are shown in the table.

Number on card	Frequency
1	8
2	11
3	10
4	9
5	12

Calculate the mean of her results.

..... [3]

- 2 (a) Jeremy goes on holiday.
He parks his car in the airport car park from

1000 on Tuesday 17 July to 1700 on Saturday 28 July.

The car park charges are shown below.

Monday to Friday	\$14 per day
Saturday and Sunday	\$8 per day
Part days are charged as full days	

Find the total cost of parking his car.

\$ [3]

- (b) At the airport, Jeremy buys a ring for \$53 and a watch for \$65.

Work out how much change he receives from \$120.

\$ [2]

- (c) The plane flies from Melbourne to Tokyo at an average speed of 783 km/h.
 The distance from Melbourne to Tokyo is 8352 km.
 The plane leaves Melbourne at 09 52 local time.
 The local time in Tokyo is 2 hours behind the local time in Melbourne.

Find the local time in Tokyo when the plane arrives.

..... [4]

- (d) In Tokyo, Jeremy buys a bracelet for 2050 yen.
 The exchange rate is 1 yen = \$0.0125 .

Calculate the price of the bracelet in dollars.
 Give your answer correct to the nearest dollar.

\$ [2]

- (e) The plane ticket costs \$680 plus a tax of 16%.

Find the total cost of this ticket.

\$ [2]

- 3 Belle records the height, in centimetres, and the mass, in kilograms, of some goats. Some of her results are shown in the scatter diagram.

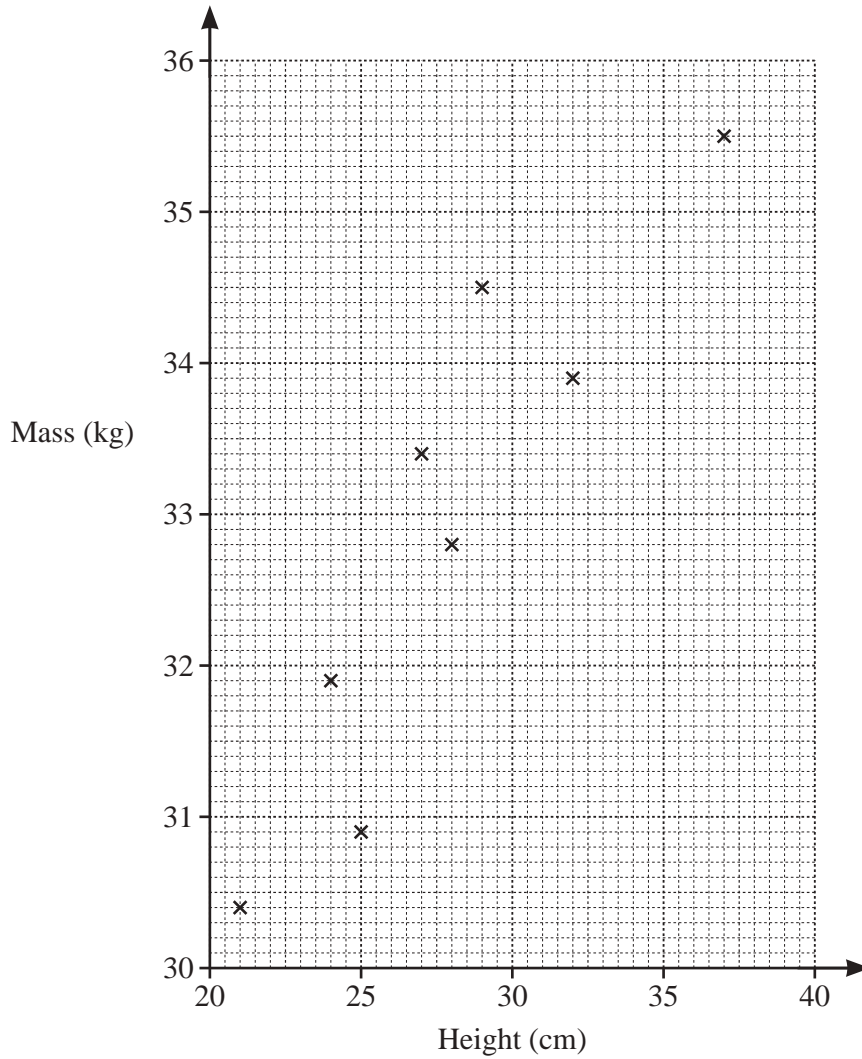

- (a) The table shows four more results.

Height (cm)	23	30	36	38
Mass (kg)	31.2	33.5	34.6	34.8

Plot these points on the scatter diagram.

[2]

- (b) What type of correlation is shown in this scatter diagram?

..... [1]

(c) (i) Draw a line of best fit on the scatter diagram. [1]

(ii) Use your line of best fit to estimate the height of a goat with mass 32.5 kg.

..... cm [1]

(d) Work out the percentage of the 12 goats that have a height between 26 cm and 35 cm.

..... % [3]

4 Alexa, Ben and Chloe own a restaurant.

(a) Alexa records some temperatures.

Fridge 4°C Cool box -3°C Freezer -19°C

(i) Find the difference in temperature between the fridge and the cool box.

..... $^{\circ}\text{C}$ [1]

(ii) Find the difference in temperature between the cool box and the freezer.

..... $^{\circ}\text{C}$ [1]

(iii) The temperature in the cold room is 5°C lower than the fridge.

Find the temperature in the cold room.

..... $^{\circ}\text{C}$ [1]

(b) Alexa, Ben and Chloe share the profits from their restaurant in the ratio $2 : 6 : 7$.

One year the restaurant makes a profit of \$60 000.

Work out how much each receives.

Alexa = \$

Ben = \$

Chloe = \$ [3]

(c) They invest \$12 000 at a rate of $n\%$ per year simple interest.

At the end of 3 years the value of the investment is \$12 900.

Find the value of n .

$n =$ [3]

5 (a) $T = 3a^2b$

Find the value of T when $a = 4$ and $b = 5$.

$T = \dots\dots\dots$ [2]

(b) (i) Multiply out the brackets.

$x(3 - 5x)$

$\dots\dots\dots$ [2]

(ii) Factorise fully.

$5x - 20x^2$

$\dots\dots\dots$ [2]

(c)

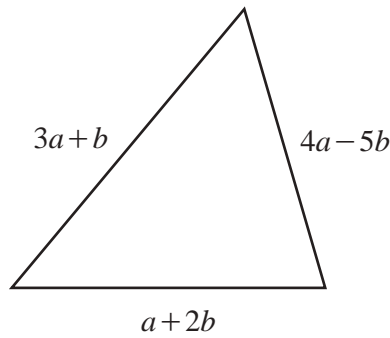

NOT TO SCALE

Find an expression for the perimeter of this triangle.
Give your answer in its simplest form.

$\dots\dots\dots$ [3]

6 (a)

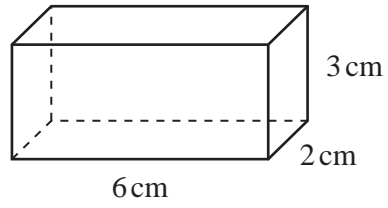
NOT TO
SCALE

The diagram shows a cuboid.

On the 1 cm^2 grid, complete the net of the cuboid.
One face has been drawn for you.

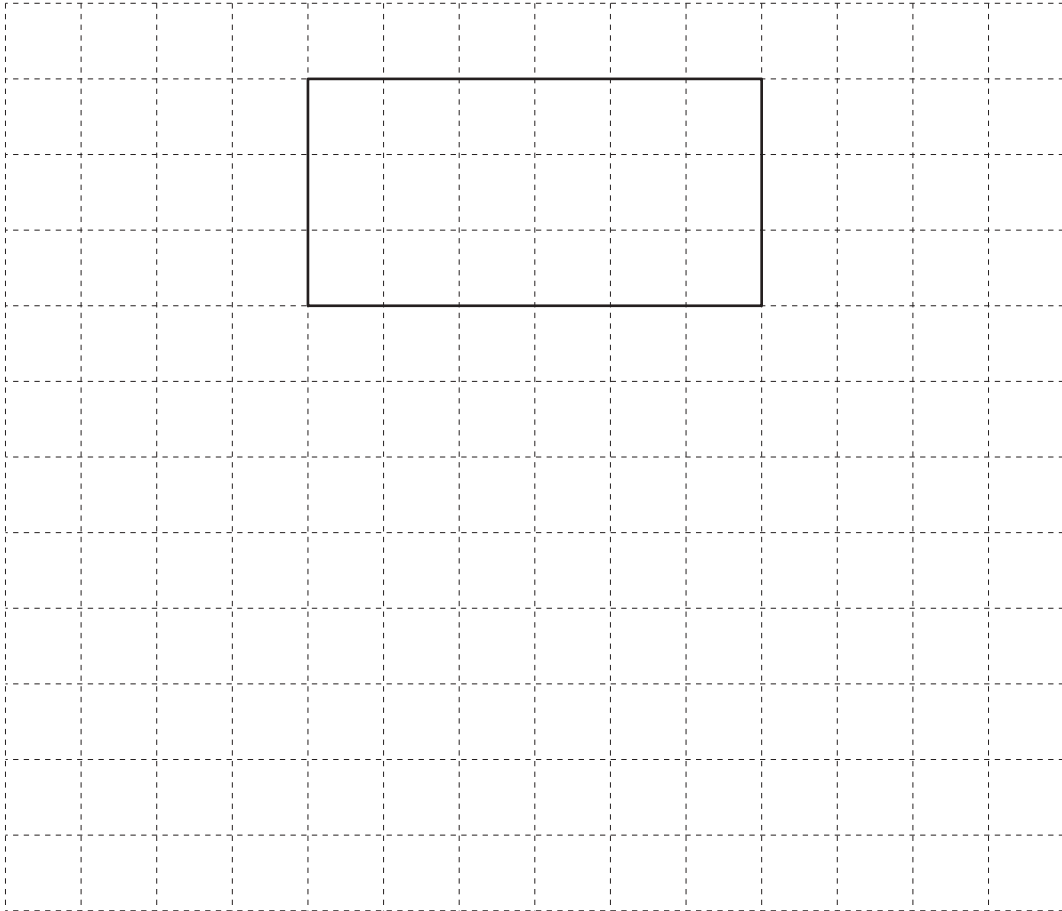

[3]

(b) A cube has a surface area of 384 cm^2 .

Find the length of one of its sides.

..... cm [3]

(c)

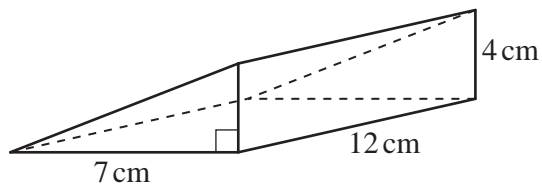

NOT TO
SCALE

The diagram shows a right-angled triangular prism.

Work out the volume of the prism.

..... cm^3 [3]

7 (a)

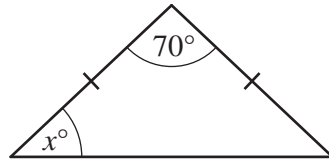

NOT TO SCALE

The diagram shows an isosceles triangle.

Find the value of x .

$x = \dots\dots\dots$ [2]

(b)

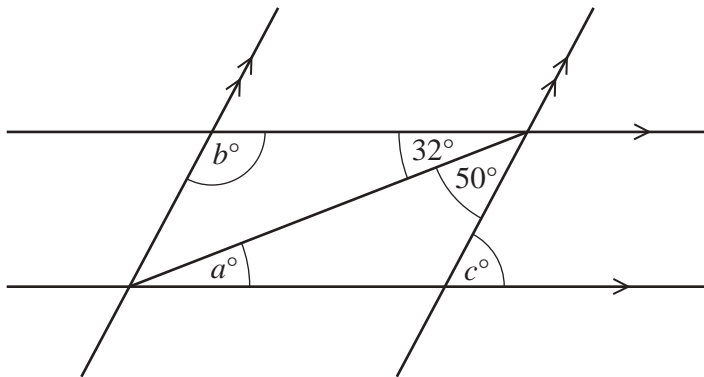

NOT TO SCALE

The diagram shows two pairs of parallel lines.

Find the value of a , the value of b and the value of c .

$a = \dots\dots\dots$

$b = \dots\dots\dots$

$c = \dots\dots\dots$ [3]

(c)

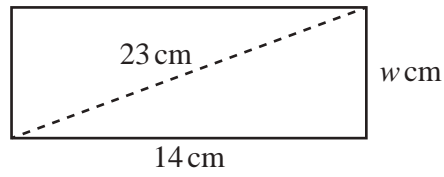

NOT TO SCALE

The diagram shows a rectangle 14 cm by w cm.
The diagonal is 23 cm.

Calculate the value of w .

$w = \dots\dots\dots$ [3]

(d)

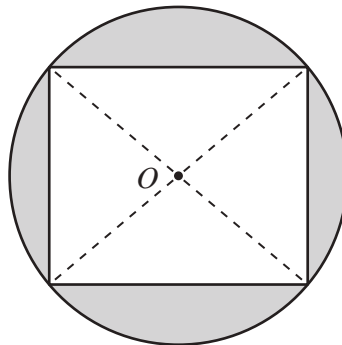

NOT TO SCALE

The diagram shows a square with vertices on the circumference of a circle, centre O .
The radius of the circle is 6 cm.

Work out the shaded area.

$\dots\dots\dots \text{ cm}^2$ [5]

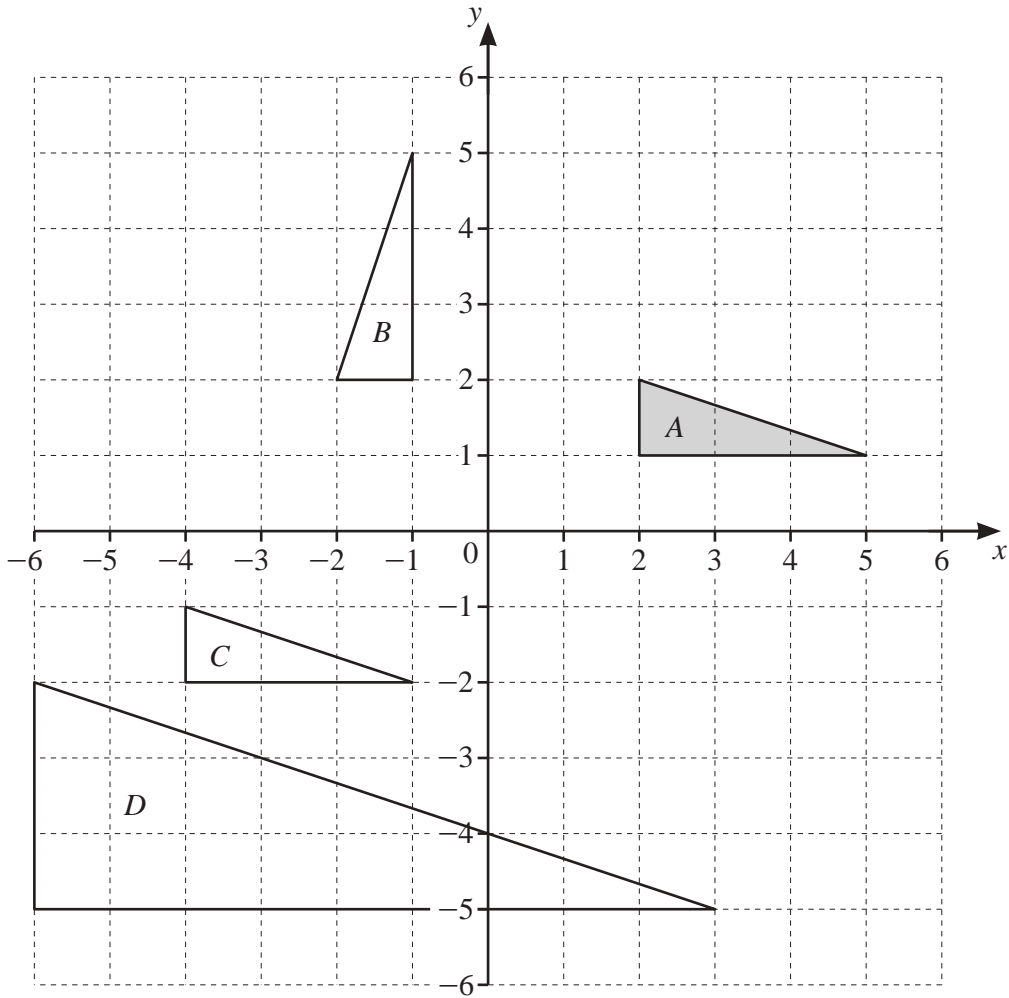

(a) Describe fully the **single** transformation that maps

(i) triangle *A* onto triangle *B*,

.....
 [3]

(ii) triangle *A* onto triangle *C*,

.....
 [2]

(iii) triangle *A* onto triangle *D*.

.....
 [3]

(b) On the grid, draw the image of triangle *A* after a reflection in the line $y = -1$. [2]

9 (a) Complete the table of values for $y = x^2 - 3x - 6$.

x	-3	-2	-1	0	1	2	3	4	5	6
y	12		-2					-2		12

[3]

(b) On the grid, draw the graph of $y = x^2 - 3x - 6$ for $-3 \leq x \leq 6$.

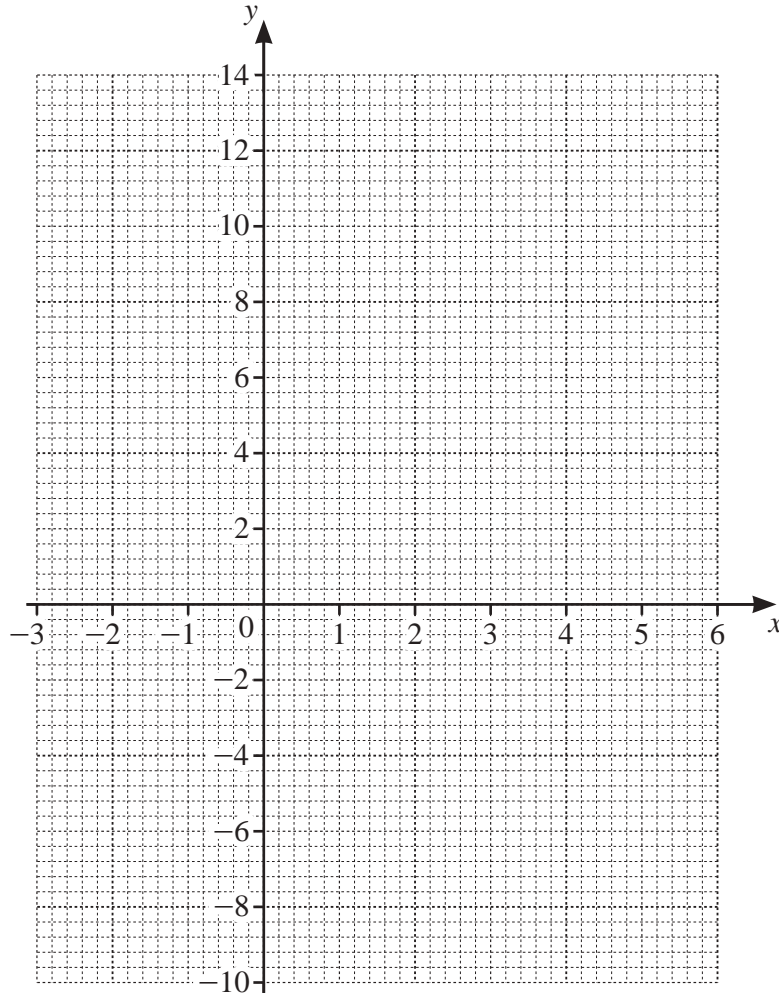

[4]

(c) Write down the equation of the line of symmetry of the graph.

..... [1]

(d) Use your graph to solve the equation $x^2 - 3x - 6 = 0$.

$x = \dots\dots\dots$ or $x = \dots\dots\dots$ [2]

Question 10 is printed on the next page.

10 (a) Solve these equations.

(i) $5x = -30$

$x = \dots\dots\dots$ [1]

(ii) $4x - 2 = 28$

$x = \dots\dots\dots$ [2]

(iii) $3(2x + 7) = 12$

$x = \dots\dots\dots$ [3]

(b) Solve the simultaneous equations.
You must show all your working.

$$\begin{aligned} 5x - 2y &= 44 \\ 2x + 3y &= 10 \end{aligned}$$

$x = \dots\dots\dots$

$y = \dots\dots\dots$ [4]

Permission to reproduce items where third-party owned material protected by copyright is included has been sought and cleared where possible. Every reasonable effort has been made by the publisher (UCLES) to trace copyright holders, but if any items requiring clearance have unwittingly been included, the publisher will be pleased to make amends at the earliest possible opportunity.

To avoid the issue of disclosure of answer-related information to candidates, all copyright acknowledgements are reproduced online in the Cambridge Assessment International Education Copyright Acknowledgements Booklet. This is produced for each series of examinations and is freely available to download at www.cambridgeinternational.org after the live examination series.

Cambridge Assessment International Education is part of the Cambridge Assessment Group. Cambridge Assessment is the brand name of the University of Cambridge Local Examinations Syndicate (UCLES), which itself is a department of the University of Cambridge.